

Silverpak 17C/CE

INTEGRATED STEP MOTOR, DRIVER, AND CONTROLLER

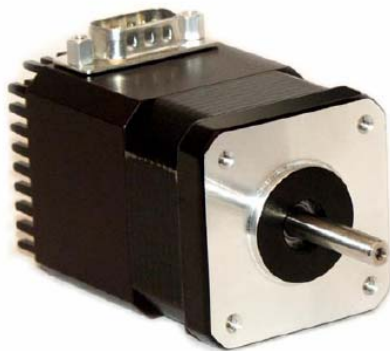

With Encoder Option

USER MANUAL
Version 1.03

Thank you for purchasing the Silverpak 17C or 17CE integrated motor and controller with microstepping driver. This product is warranted to be free of manufacturing defects for one year from the date of purchase.

Technical Support for Lin Engineering

By Telephone: 408-919-0200

(Mon.-Fri., 8:00 a.m.-5:00 p.m.)

On the Web: www.linengineering.com

Our technical support group is glad to work with you in answering your questions. If you cannot find the solution to your particular application, or, if for any reason you need additional technical assistance, please call technical support at **408-919-0200**.

PLEASE READ BEFORE USING

Before you begin, ensure there is a suitable DC Power Supply. **Do not disconnect the DB-9 cable while power is still being applied to the controller.** This will damage the board. Under any circumstances, do not exceed +40 VDC.

DISCLAIMER

The information provided in this document is believed to be reliable. However, no responsibility is assumed for any possible inaccuracies or omissions. Specifications are subject to change without notice.

Lin Engineering reserves the right to make changes without further notice to any products herein to improve reliability, function, or design. Lin Engineering does not assume any liability arising out of the application or use of any product or circuit described herein; neither does it convey any license under its patent rights, nor the rights of others.

There are known issues involving the Halt command (i.e., H01) when stored in memory location zero. Upon power up, the remaining command string after the Halt command might be executed if the user types in a new command. If memory location zero is not being used, the user is advised to always clear everything in memory by typing `/1?9`. Otherwise, the user may terminate the remaining command string in the buffer by issuing a `/1T`.

Special Symbols



Indicates a WARNING and that this information could prevent injury, loss of property, or even death (in extreme cases).

Silverpak 17C/CE User Manual

Product: Silverpak 17C and 17CE
Version: 1.03
Date: 2/1/2007

Version History		
Version	Date	Description of Changes
1.00	04/10/2006	New User Manual
1.01	08/07/2006	Updated specs
1.02	08/18/2006	Updated specs
1.03	02/01/2007	Standardization of all user manuals

TABLE OF CONTENTS

1. FEATURES 5

Designer's Kit (083-00004) with RS232 comm 5

Designer's Kit (083-00026) with USB comm 5

Silverpak 17CE Encoder Pinouts 5

Default Settings 6

2. ELECTRICAL SPECIFICATIONS 6

Digital I/O Specifications 6

Motor Specifications 6

3. OPERATING SPECIFICATIONS 6

Communication Specifications 6

4. MECHANICAL SPECIFICATIONS 7

Dimensions 7

5. PIN ASSIGNMENTS 8

Connecting to the RS232 card 8

Connecting to the USB card 9

6. CONNECTION SPECIFICATIONS 10

Quick Start 10

RS232-485 converter card 10

USB-485 converter card 10

Mating Connectors 11

7. CONFIGURING AND CONTROLLING THE Silverpak 11

HyperTerminal Setup 11

Setting the Current 12

Connecting Multiple Silverpak17C's 13

Changing the Address of the Controller 13

Connecting Accessories 14

Push Button 14

Optical Sensor 15

Encoder Usage 16

1. FEATURES

- NEMA 17, 1.8° step motor integrated with R256 controller/driver
- Operates from +12V to 40V
- Single 4 wire bus linking up to 16 stepper motors
- 2.0 Amp Chopper (PWM) Driver
- 1/2, 1/4, 1/8, 1/16, 1/32, 1/64, 1/128, 1/256 step resolution
- Stand alone operation with no connection to a PC
- Execution Halt pending switch push button
- Pre-wired for Opto Switch inputs
- Homes to an Opto or Switch closure with a single command
- Fully programmable ramps and speeds
- Two digital I/O and two fixed input channels
- Switch selectable address
- Software selectable "Move" and "Hold" currents
- Hold Current automatically selected upon move completion
- Simple DB9 connection

Designer's Kit (083-00004) with RS232 comm

Here is the list of components if you have purchased the optional Designer's Kit:

- RS485 to RS232 converter card
- A DB-9 female connector cable, a switch push button, Opto Sensor, a 4 Pin connector for the converter card
- CD-ROM with Manuals and Software

Designer's Kit (083-00026) with USB comm

Here is the list of components if you have purchased the optional Designer's Kit:

- USB to RS232 converter card
- A DB-9 female connector cable, a switch push button, Opto Sensor, a 3 Pin connector for the converter card, a USB 6 foot long cable, a 3-Pin to 3-Pin cable
- CD-ROM with Manuals and Software

Silverpak 17CE Encoder Pinouts

NOTE: This is not a closed loop system. The encoder does not feedback to the controller. A separate PLC or controller must be used to communicate between this controller and this encoder.

- A choice of 32 to 1250 cycles per revolution (CPR)
- 2 Channel Quadrature
- TTL Squarewave Outputs
- Optional index (3rd Channel)
- E2 US Digital Encoder

Pin Number	Function
1	Ground
2	Index*
3	Channel A
4	+ 5 VDC
5	Channel B

Table 1: Encoder Pinouts

*Optional, upon request

Default Settings

Function (command)	Description
Running Current (m)	30% of 2.0 Amps
Holding Current (h)	10% of the run current
Step Resolution (j)	256x
Top Velocity (V)	305175 pps (microsteps/sec)
Acceleration (L)	L=1000, 6103500 μ steps/sec ²
Position	0
Microstep smoothness (o)	1500
Outputs (J)	Both are turned off, J0
Baud Rate	9600 bps

Table 2: Default Settings

2. ELECTRICAL SPECIFICATIONS

Supply Voltage: +12 to +40 VDC
Peak Current: 0.1 to 2.0 Amps

Digital I/O Specifications

Number of I/O 2
Number of Inputs 2
Input Voltage +0 VDC to +5 VDC (0 to 24V tolerant, but 5V recommended)
Input Current 700 mA
Pull-up Resistors 10k Ω
Protection Static Protection to the microprocessor

Motor Specifications

Any 4118 series step motor that is rated at 2.0 Amps/Phase or less can be combined into a Silverpak 17C or CE product. General torque specifications are listed below:

Holding Torque (max of 1.0 Amp Holding Current, winding specific)
CO-4118S 20 to 45 oz-in
CO-4118M 30 to 63 oz-in
CO-4118L 40 to 80 oz-in

Steps per Revolution: 400, 800, 1600, 3200, 6400, 12800, 25600, 51200

3. OPERATING SPECIFICATIONS

Maximum Step Frequency 2^{24} (pps) or 16.7MHz
Operating Temperature Range 0° to 50° C
Storage Temperature Range -20° to 70° C

Communication Specifications

Interface Type RS485 (RS232 or USB with a converter card)
Baud Rate 9600*, 19200, or 38400 bps
Bits per character 8 Data
Parity None
Stop Bit 1
Flow Control None

*default

4. MECHANICAL SPECIFICATIONS

Dimensions

- A. DB-9 connector for I/O, Power and Communication
- B. Motor Shaft Length
Standard length is 0.94". Customized length is available.
- C. Motor Shaft Diameter
Standard shaft diameter is 0.1968". Customized diameter length available.
- D. Overall Body Length
Motor body length is available in various lengths
Model CO-4118S (2.69")
Model CO-4118M (2.92")
Model CO-4118L (3.24")
- E. Encoder Pinouts

Pin Number	Function
1	Ground
2	Index*
3	Channel A
4	+ 5 VDC
5	Channel B

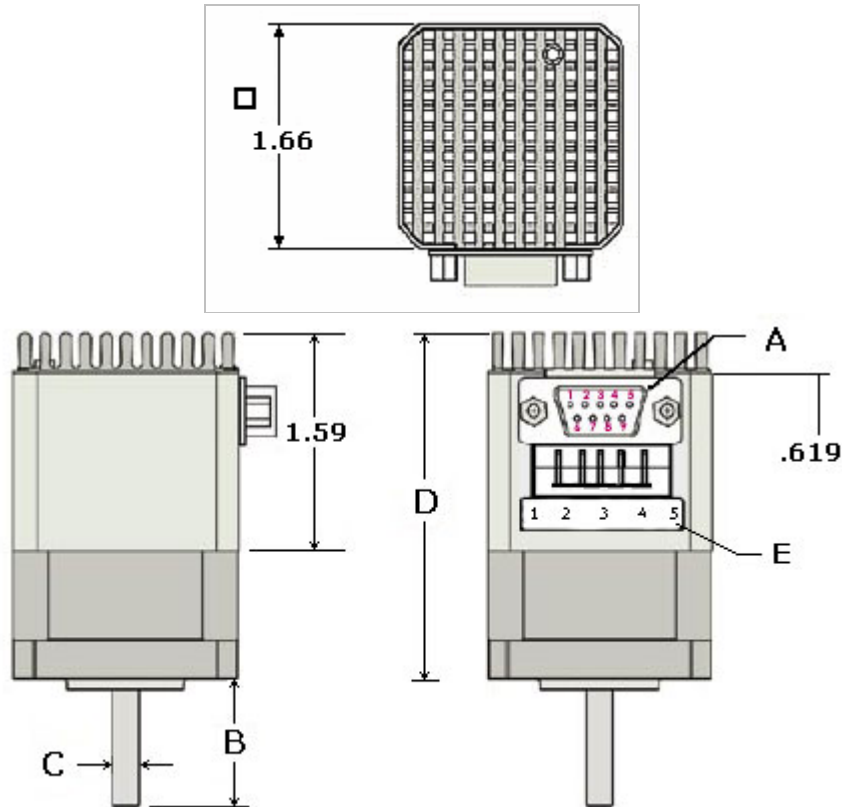

**Index is optional*

5. PIN ASSIGNMENTS

A DB-9 female connector cable receives power and provides the control connections for the Silverpak17C. The DB-9 cable has a 4 pin connector provided for the converter card in order for the controller to communicate with the PC via RS232. For the USB communication, there should be a white 3-Pin connector. Other wires allow the user to solder and program the switch push button and the Opto Sensor, enabling several options. The I/O's will allow for options such as solenoids, relays, opto isolators, LED's and many other input and output connections. See *Table3* below for details.

Pin #	Color	Function	Input *
1	Red	+V (Main Power In)	
2	Black	I/O	1
3	Brown	RS485B (-)	
4	Black/White	RS485A (+)	
5	Orange	Switch Closure to GND (IN)	4
6	Green	GND (-V of main power in)	
7	White	Opto Sensor Phototransistor (IN)	3
8	Blue	I/O	2
9	Yellow	Opto Sensor LED (Power Out)	

Table 3: Pin Assignments

*Inputs are labeled 1, 2, 3 and 4 for programming the 'Halt' and 'Skip' Commands.

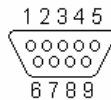
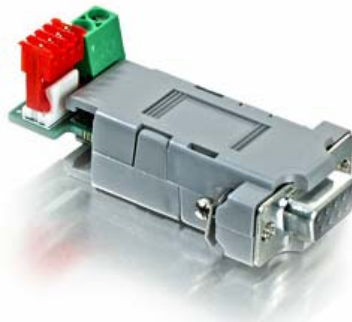

Figure 2: DB-9 Female Cable Connector (Rear View)

Connecting to the RS232 card

SP17C pin#	SP17C color	RS232 card pin#
4	Black/white	A (RS485A)
3	Brown	B (RS485B)
6	Green	- (GND)
1	Red	+ (PWR)



The RS232 card requires power (7-40VDC). Power is then sent to the motor via the Red 4-Pin connector.

Connecting to the USB card

SP17C pin#	SP17C color	*USB pin#
4	Black/white	1 (RS485A)
6	Green	2 (GND connect to Power Supply Ground)
3	Brown	3 (RS485B)

*Where Pin #1 is located here:



RS485 Connection View

The USB converter card does not require power (it receives power from the PC). Power is still needed for the R256 controller/driver.



6. CONNECTION SPECIFICATIONS

Quick Start

DO NOT PLUG IN POWER UNTIL EVERYTHING IS CONNECTED.

RS232-485 converter card

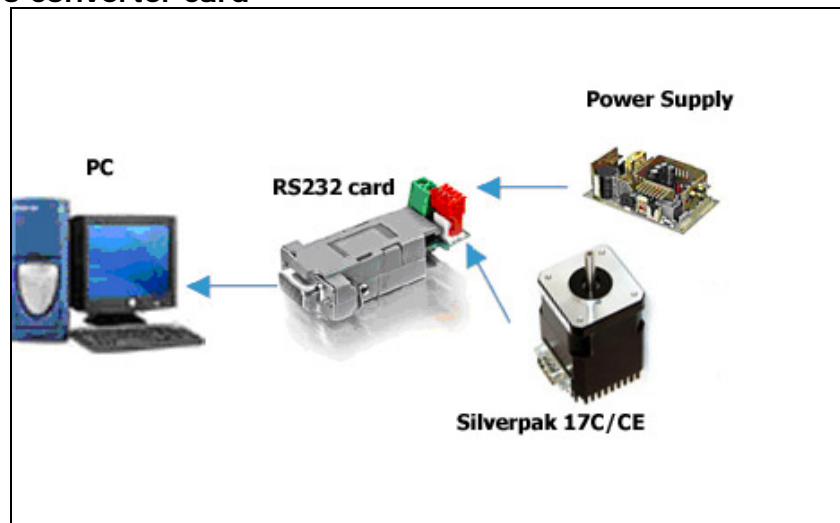

1. The RS232 converter card connects to the Silverpak using the DB-9 cable that is provided to you. The red 4-Pin connector is placed onto the converter card.
2. Your power supply will be connected to the RS232 card where the green header is located. **+ is for +12-40VDC, - is for the Power Supply Ground.**
3. Connect the RS232 card to your PC with a female to female DB-9 cable.
4. Turn your power supply on and follow instructions for using HyperTerminal.

USB-485 converter card

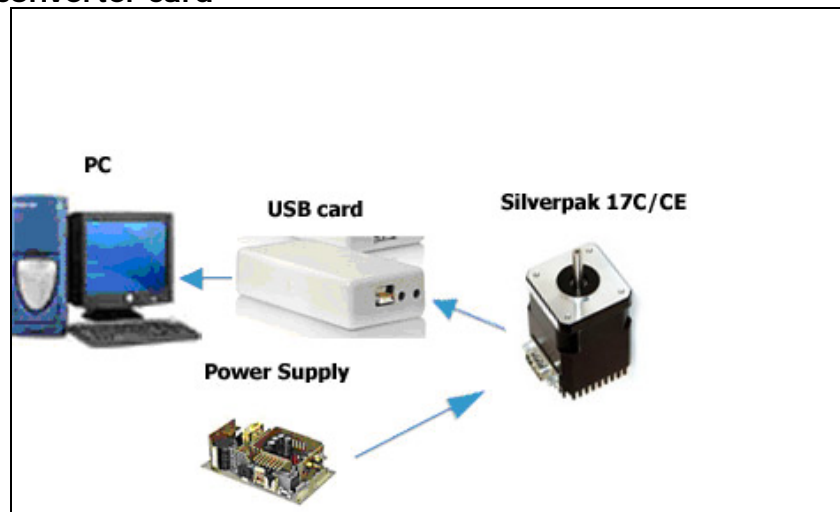

1. The USB converter card connects to the Silverpak using the DB-9 cable that is provided to you. The white 3-Pin connector is placed onto the converter card.
2. Your power supply will be connected to the Silverpak directly. The USB card is powered via the PC. **Silverpak's pin1, Red wire is +12-40VDC, pin 6, Green wire is Ground.**
3. Connect the USB card to your PC using the USB cable provided to you. You will need to download driver files (2 of them). You can find them at: <http://www.linengineering.com/site/products/usb485.htm>
4. Turn your power supply on and follow instructions for using HyperTerminal.

Mating Connectors

A mating D-Sub connector and crimp style connector are provided.



Part # 90-022

(Part # 90-044 is the DB-9 cable that has a white 3-Pin header for the USB card).

7. CONFIGURING AND CONTROLLING THE SILVERPAK 17C

HyperTerminal Setup

Please follow these steps in order to properly set up HyperTerminal:

1. Open a terminal from your PC by following these steps: Start Menu → Programs → Accessories → Communications → HyperTerminal
2. Assign a name for your New Connection
3. Under 'Connect using', select the COM connection that corresponds to your PC serial port (i.e. COM 1, COM 2, etc.) then click 'OK'
4. Set your Port Settings to default (i.e. 9600 baud, 8 data, no parity, 1 stop bit, no flow control)
5. Turn on local echo by going to: File → Properties → Settings tab → ASCII Setup: Click on the box for "Echo Typed Characters Locally" and click on the box for "Send Line ends with line feeds". Click "OK".
6. Now you can type your commands
7. Example: /1A1000R
 - This will run Driver 1 to the Absolute position 10000
 - You can check the address of your driver by checking the dial at the top of the driver. (See the following page for Changing the Address)
 - A full list of commands is available in the R256 Command List

HyperTerminal Responses:

/0@□ indicates good command and that it was received correctly
/0b□ indicates bad command
/0C□ indicates that the command is out of range
/0'□ indicates that the command is terminated
/0O□ Overflow

Setting the Current



CAUTION! DO NOT SET THE CURRENT ABOVE THE MOTOR'S RATED CURRENT.

In order to set the correct current for your motor, you must program the specified amount in HyperTerminal

Current is set based on the Maximum amount of current the controller board can output, which is 2.0 Amps Peak. Below is a table of how much current will be applied to your motor for each setting.

Percent		Motor's Current Rating (Amps)	Driver's Equivalent Current (Amps)
10%	=	0.14	0.20
20%	=	0.28	0.40
30%	=	0.42	0.60
40%	=	0.57	0.80
50%	=	0.70	1.00
60%	=	0.85	1.20
70%	=	0.99	1.40
80%	=	1.13	1.60
90%	=	1.27	1.80
100%	=	1.41	2.00

Table 3: Desired Current

To achieve the equivalent Driver Current (Amps), multiply your motor's rated current by 1.4. Follow these examples:

Example One:

You have a motor that is rated at **0.85** Amps, $0.85 \text{ Amps} \times 1.4 = \sim 1.2 \text{ Amps}$. Using *Table 3* we would see that 1.2 Amps is 60% of the driver's maximum output current.

Assuming the Silverpak is addressed to Number 1, this is what you'd program:
`/1m60R`

Example Two:

You have a motor that is rated at **1.0** Amps, and your Controller is addressed to Number 1, this is what you'd program: `/1m70R`

This will set the controller to 1.4 Amps Peak. How did we get 1.4 Amps? $\rightarrow 1.0 \text{ Amps} \times 1.4 = 1.4 \text{ A}$

WARNING!: Setting the Current to a value greater than the Motor's rated current will damage your motor, and may overheat the controller.

Connecting Multiple Silverpak17C's

Connect multiple controllers by using the Converter card, shown below:

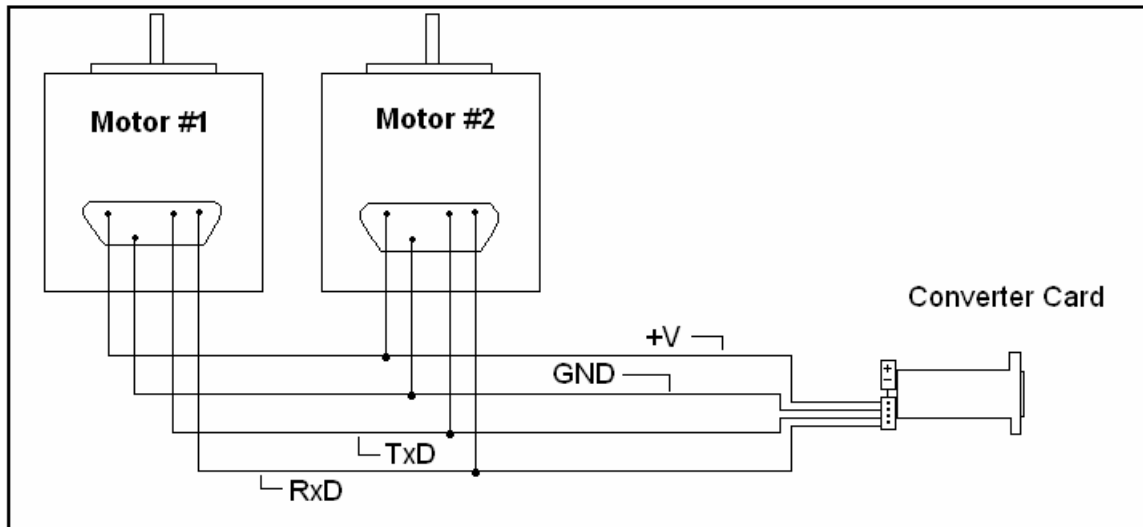

Changing the Address of the Controller

Use a screwdriver to turn the dial so the arrow points to the desired Address. Use this number when programming commands. For example, /1P1000R



Figure 5: Address Dial

Note: New RoHS compliant boards have a **Black** dial instead of a Red one.

Connecting Accessories

If you have purchased the Designer's Kit, there is a Red Push Button and an Optical Sensor included. Follow the schematics below in order to properly assemble accessory pieces.

Push Button

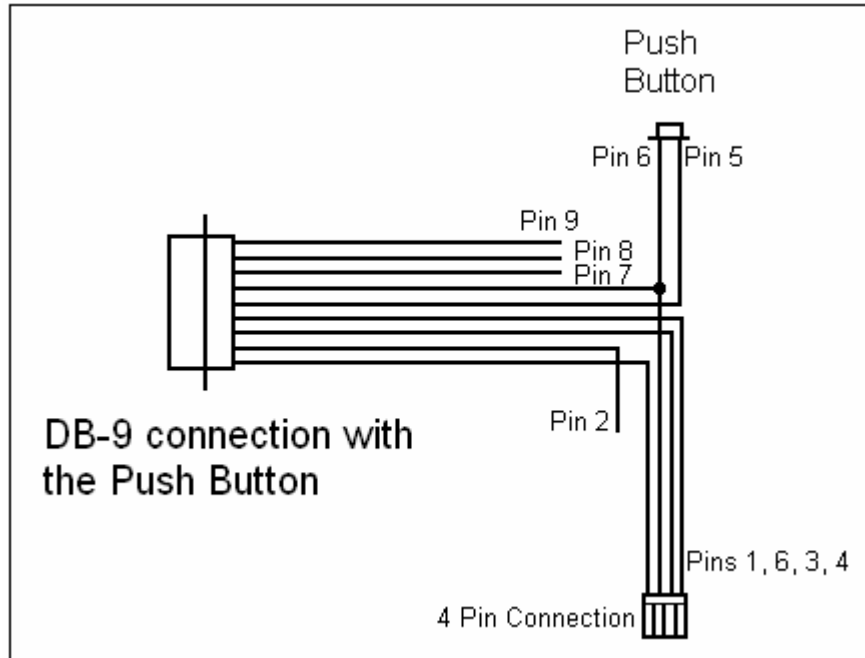

Figure 6: Push Button Schematic

It is best to solder the Push Button to Pin 5 which corresponds to Input 4, then solder Pin 6 (Power Ground) to the other side of the push button.

Input 1	Pin 2
Input 2	Pin 8
Input 3	Pin 7
Input 4	Pin 5

Table 4

Optical Sensor

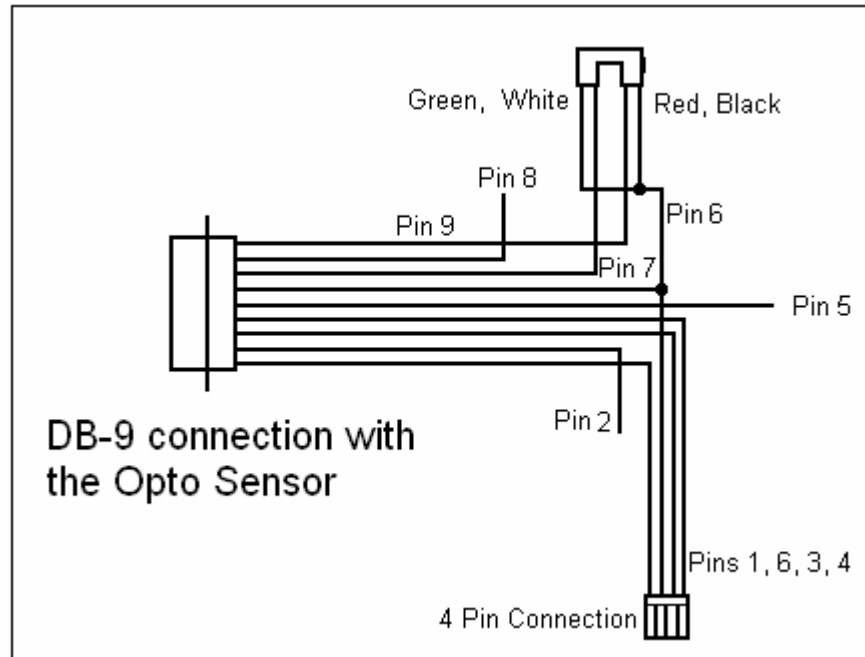

Figure 7: Opto Sensor Connection Schematic

The Opto Sensor uses Pins 6, 7, and 9. Use the following table to solder the corresponding wires.

Optical Sensor	DB9 Cable
Green →	Green
Black →	Green
Red →	Yellow
White →	White

Table 5

Encoder Usage

The Silverpak 17CE is **not a closed loop system**. The encoder does not connect to the controller/driver. A separate PLC or controller system that can talk to the R256 board and understand the E2 encoder can create a closed loop system.

The Silverpak 17CE can also be used as reference to home by connecting to an US Digital E2 Encoder. The pinouts are as follows:

Pin Number	Function
1	Ground
2	Index
3	Channel A
4	+ 5 VDC
5	Channel B

The E2 encoder requires a separate +5 Volt power supply, as the Silverpak17CE cannot provide a strong enough source of power.

In order to use the Indexer as a reference to home, connect Pin 2 from the encoder to one of the inputs on the controller. From the controller's side, for best results use Pin 5, the switch closure to ground.

In addition, use a pull-down resistor (10k Ω) to ensure that the controller will recognize the difference between high and low (4.85V and 0.5V).

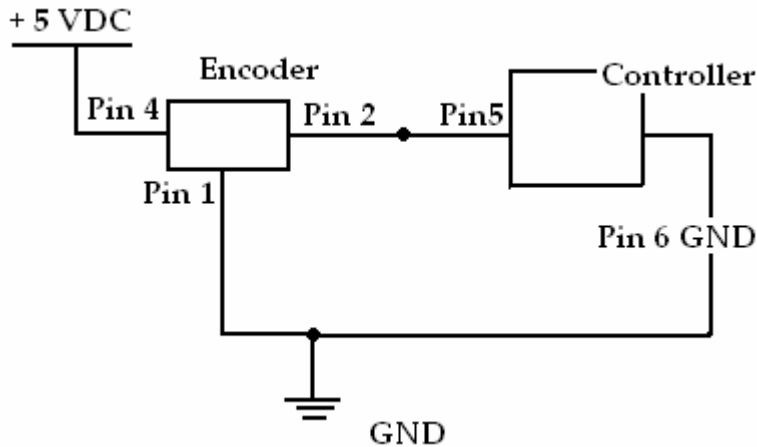

Figure 8: Encoder Pin Connection Schematic

After successfully connecting the encoder to the controller, now you can program the controller to run continuously. The motor will stop movement when the indexer goes high. This will send the high signal to Pin 5 on the controller.

If using channel 1, use this command to start the homing routine:

```
/1P0R
```

8. Troubleshooting & FAQ

Cannot Type anything in HyperTerminal:

Is the correct COM Port selected? Are you using Windows 95? Windows 95 has had problems with its HyperTerminal. Use an operating system of Windows 98 or higher. Are you working on a Laptop? Sometimes there is a shift in Ground on Laptop Serial Ports. Pin 5 on the Serial Port is Ground. Make sure that this is connected to a true ground.

Did you check the Properties in HyperTerminal? Check the box in Properties → ASCII Settings → ASCII setup → 'Echo Typed Characters Locally'.

Is the LED flashing on the bottom of the Silverpak17C? A flashing light indicates it is waiting for Commands and power is OK. Motor shaft should be difficult to rotate.

Check the Converter Card. Use a voltmeter to measure if Power is coming into the card correctly and if power is being supplied to the Controller properly.

Can Type in HyperTerminal, but nothing is happening:

Check the LED on the back of the Silverpak 17C. If there is no LED lit, the problem may be the Power Supply, check the connections. If you see one LED that flashes on and off about 5 seconds at a time, then power is OK.

Is the Silverpak17C set to the correct Address? Check the Red Dial (new RoHS compliant boards have a black dial) on the bottom of the unit. The white arrow should be pointing to the corresponding Address. Make sure that the arrow is not between 2 Addresses. Use a small screw to verify that it clicks in place.

Check the Converter Card. Use a voltmeter to measure if Power is coming into the card correctly and if power is being supplied to the Controller.

Assuming the Properties of HyperTerminal are set as described in the Manual (HyperTerminal Setup), does HyperTerminal respond with a string of characters?

/0'□ indicates that the command is terminated

/0@□ indicates good command and that it was received correctly

/0C□ indicates that the command is out of range

/0b□ indicates bad command

The unit is by default, set to 256 microsteps. Therefore, by typing in a position move of /1P200R, you will not see anything. It takes 51,200 steps to make one revolution, so try a large value, like /1P100000R

Windows Application: When pressing 'Run' it gives the error - File Already Open:

Another program could also be running at the same time. Click End, and then try again. Sometimes if you are connected through a Network, there are problems with permissions in running programs. Check with your Administrator.

If HyperTerminal is open concurrently, you will receive an error. Only one program can be running at one time.

Silverpak 17C will accept commands, but the Motor will stall in the middle of a command:

This means there is not enough current being supplied to the Motor. Use the m command to change the current, or run the Motor at a Lower Speed (V command). Or, make the motor accelerate slower using the L command.

Halt Command (H01) Issues

There are known issues involving the Halt command (i.e., H01) when stored in memory location zero. Upon power up, the remaining command string after the Halt command might be executed if the user types in a new command. If memory location zero is not being used, the user is advised to always clear everything in memory by typing /1?9. Otherwise, the user may terminate the remaining command string in the buffer by issuing a /1T.

I want to use one of the I/Os to turn on a LED to confirm that the motor has finished moving or moved to a certain position. How do I do it?

To turn on a LED to confirm that the motor finished moving you must use the "J" command in the command list section On/Off Drivers. We are assuming the unit executes the command sent. We cannot detect skipping because the set up is open loop. Example: /1P200J10R, is a position move 200 steps, then turn on driver 2.

What's the minimum and maximum voltage the RS485 to RS 232 Converter Card can handle?

Min and Max voltage levels: 7 to 40 VDC

Using a PLC to communicate with board

After the command, you need to issue a carriage return and linefeed.

Example: /1A1000R (absolute position move 1000). After the R, send a 0x0d in hex.

USB Converter card setup

The USB converter card requires you to install the unit as a hardware. Two files should be downloaded, and they can be found online at www.linengineering.com → Products → Step Motors → USB485 Card → Downloads → Driver files.

You should be able to view the converter card if you go to Properties of "My Computer" → Hardware → Device Manager → Ports.



The LED's on the USB485 converter card only light up during sending and receiving of a command.