

Commands List for

Silverpak 23C Integrated motor + control/drive

Silverpak 23CE Integrated motor + control/drive + encoder

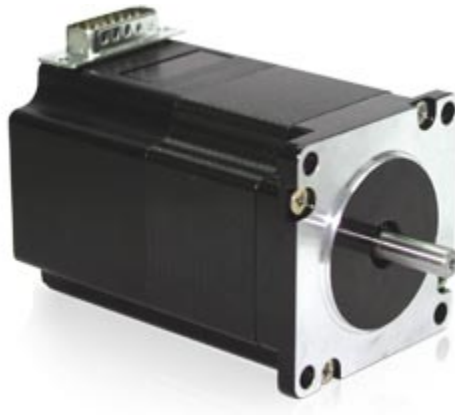

Version 1.08

Thank you for purchasing the Silverpak 23C or 23CE integrated motor and controller/driver with optional encoder feedback (23CE). This product is warranted to be free of manufacturing defects for one year from the date of purchase.

Technical Support for Lin Engineering, a distributor for RMS Technologies

By Telephone: 408-919-0200

(Mon.-Fri., 8:00 a.m.-5:00 p.m.)

On the Web: www.linengineering.com

Our technical support group is glad to work with you in answering your questions. If you cannot find the solution to your particular application, or, if for any reason you need additional technical assistance, please call technical support at **408-919-0200**.

PLEASE READ BEFORE USING

Before you begin, ensure there is a suitable DC Power Supply. **Do not disconnect the DB-15 cable while power is still being applied to the controller.** This will damage the board. Under any circumstances, do not exceed +40 VDC.

DISCLAIMER

The information provided in this document is believed to be reliable. However, no responsibility is assumed for any possible inaccuracies or omissions. Specifications are subject to change without notice.

Lin Engineering reserves the right to make changes without further notice to any products herein to improve reliability, function, or design. Lin Engineering does not assume any liability arising out of the application or use of any product or circuit described herein; neither does it convey any license under its patent rights, nor the rights of others.

There are known issues involving the Halt command (i.e., H01) when stored in memory location zero. Upon power up, the remaining command string after the Halt command might be executed if the user types in a new command. If memory location zero is not being used, the user is advised to always clear everything in memory by typing `/1?9`. Otherwise, the user may terminate the remaining command string in the buffer by issuing a `/1T`.

Special Symbols



Indicates a WARNING and that this information could prevent injury, loss of property, or even death (in extreme cases).

Silverpak 23C/CE Commands User Manual

Product: Silverpak 23C/23CE
Version: 1.08
Date: 07/17/2007

Version History		
Version	Date	Description of Changes
1.00		New User Manual
1.01		Corrected m to be 3.0Amps not 2.0Amps
1.02		Added extra note about step & direction mode
1.03		Removed c command
1.04		Updated pinouts, updated encoder info, o command range, updated wording of Z command.
1.05		Added example for Opto and Jog Mode and added B command
1.06	2/28/2007	Standardization of manuals
1.07	4/13/2007	Velocity range, explanation of commands more in detail
1.08	07/17/2007	Updated response codes

TABLE OF CONTENTS

DT Protocol syntax 5

Running two or more motors together 5

Default Values 5

List of Commands 6

HOMING & POSITIONING 6

VELOCITY & ACCELERATION 6

SETTING CURRENT 7

LOOPING & BRANCHING 7

POSITION CORRECTION – ENCODER OPTION ONLY 9

PROGRAM STORAGE & RECALL 9

PROGRAM EXECUTION 9

MICROSTEPPING 9

BAUD CONTROL 10

Responses from Controller in HyperTerminal 11

Understanding Response 12

Homing Sensor 14

APPENDIX 1 15

Encoder Usage 15

Position Correction Mode 15

Overload Report Mode 15

APPENDIX 2 16

STEP AND DRIVE MODE 16

DT Protocol syntax

The DT Protocol allows the unit to be commanded over a simple serial port.

Start Character	Address	Commands	Run	End of a string
/	1-9*	Command strings	R	<CR>

*To Access Drivers 10 – 16 use the following:

Driver #	Command	
A	:	(colon)
B	;	(semi colon)
C	<	(less than)
D	=	(equals)
E	>	(greater than)
F	?	(question mark)
0	@	(at sign)

Running two or more motors together

Motors 1 and 2:	"A"	
Motors 3 and 4:	"C"	
Motors 5 and 6:	"E"	
Motors 7 and 8:	"G"	
Motors 9 and 10:	"I"	
Motors 11 and 12:	"K"	
Motors 13 and 14:	"M"	
Motors 15 and 16:	"O"	
Motors 1, 2, 3 and 4:	"Q"	
Motors 5, 6, 7 and 8:	"U"	
Motors 9, 10, 11 and 12:	"Y"	
Motors 13, 14, 15 and 16:	"]"	(close bracket)

For all motors: "_" (underscore)

Example: /CA5000R will move motors 3 and 4 to Absolute Position 5000.

Default Values

Function (command)	Description
Running Current (m)	30% of 2.0 Amps
Holding Current (h)	10% of the run current
Step Resolution (j)	256x
Top Velocity (V)	305175 pps (microsteps/sec)
Acceleration (L)	L = 1000, 6103500 μ steps/sec ²
Position	0
Microstep smoothness (o)	1500
Outputs (J)	Both are turned off, inputs 1 & 2
Baud Rate	9600 bps

List of Commands

Command (Case Sensitive)	Operand	Example	Description
HOMING & POSITIONING			
Z	0-10000	/1Z1000R	Initialize the Motor. Motor will turn towards 0 until the home opto sensor is interrupted. If already interrupted it will back out of the opto and come back in until re-interrupted. Current motor position is set to zero. Speed of homing is set by V. In the example, the motor will take 10000 steps to find the home sensor. If sensor is still not found after 10000 steps, it will stop motion.
z	0-max*	/1z65536R	Sets current position without moving motor
A	0-max*	/1A1000R	Move Motor to Absolute position. i.e. moves to the 10,000 th step. Issuing A10000 again will NOT move the motor because it is already at that location.
f	0 or 1	/1f1R	Flag polarity. Sets polarity of direction of home sensor, default is 0.
P	0-max*	/1P1000R	Move Motor relative number of steps in positive direction. A "P0" command rotates motor infinitely, which enters into Velocity Mode. Any other finite number will set the mode to be in Position Mode.
D	0-max*	/1D1000R	Move Motor relative number of steps in negative direction (Note: Motor will not run in the negative direction if the position is at 0. You can use the 'z' command to set the 0 position to be further away in the negative direction. OR you can use the F command to reverse direction of rotation.) A "D0" command rotates motor infinitely, which enters into Velocity Mode. Any other finite number will set the mode to be in Position Mode.
B	0-max*	/1B1000R	Sets the distance for pulse jog mode (see n command)
T		/1TR	Terminate current command
F	0, 1	/1F1R	Reverses the positive direction to be negative. The P and D command will switch directions. Default is 0.
*	2 ³¹		Max value is 2 ³¹ = 2,147,483,648
VELOCITY & ACCELERATION			
V	0-2 ³¹	/1V2000R	In Position Mode, this sets the Top Speed of the Motor in μsteps/sec . During velocity mode, speed can be changed on the fly (during rotation).
L	0-65000	/1L5000R	This sets the Acceleration factor μsteps/sec² = (L Value) x (6103.5). i.e. /1L1R takes 16.384 Seconds to get to a speed of V=100000 (μsteps/sec) Default is L=1000, default speed V = 305175 μsteps/sec, so default acceleration = 6103500 μsteps/sec ² . It should take 0.05 seconds to get to top speed.

Command (Case Sensitive)	Operand	Example	Description
SETTING CURRENT			
m	0-100	/1m50R	Sets the running current on a scale of 0 to 100% of the max current, 3.0A. Default setting is m30.
h	0-50	/1h20R	Sets the Hold Current on a scale of 0 to 50% of the max current, 3.0 Amps. Default setting is h10.
LOOPING & BRANCHING			
g		/1gP10G5R	Beginning of a repeat loop
G	0-30000	/1gP10G0R	End of a repeat loop. Loops can be nested up to 4 levels. A value of 0 causes the loop to be infinite.
M	0-30000	/1M2000R	Delay for "M" milliseconds
H	01 11 02 12 03 13 04 14	/1gH02P100 00G20R	<p>Halt current command string and wait until condition specified. Example will wait for switch two (2) to close (0)</p> <p>01 Wait for low on input 1 (Pin 13) 11 Wait for high on input 1 (Pin 13) 02 Wait for low on input 2 (Pin 5) 12 Wait for high on input 2 (Pin 5) 03 Wait for low on input 3 (Pin 7) 13 Wait for high on input 3 (Pin 7) 04 Wait for low on input 4 (Pin 14) 14 Wait for high on input 4 (Pin 14)</p> <ul style="list-style-type: none"> • Halted operation can also be resumed by typing /1R • Only input 2 can stop motion of a P0 or D0 command
S	01 11 02 12 03 13 04 14	/1gS02A100 00A0G20R	<p>Skip command: will skip the command following it if the input is high or low.</p> <p>Useful for executing different programs based on a high or low signal on an input.</p> <p>01 Skip next instruction if low on input 1 (Pin 13) 11 Skip next instruction if hi on input 1 (Pin 13) 02 Skip next instruction if low on input 2 (Pin 5) 12 Skip next instruction if hi on input 2 (Pin 5) 03 Skip next instruction if low on input 3 (Pin 7) 13 Skip next instruction if hi on input 3 (Pin 7) 04 Skip next instruction if low on input 4 (Pin 14) 14 Skip next instruction if hi on input 4 (Pin 14)</p>

Command (Case Sensitive)	Operand	Example	Description
n	0-4095	/1n2R	<p>Sets Modes – Interpret as combination of Binary Bits</p> <p>Bit0: /1n1R Enable Pulse Jog Mode. Jog distance is given by “B” command. Velocity is given by “V” command . The Switch Inputs 1 and 2 become the Jog Inputs. Press input 1 to rotate CW for a given distance, B. Press input 2 to rotate CCW for a given distance, B.</p> <p>Bit1: /1n2R Enable Limit. The opto input #3, pin 7, becomes one limit switch. Use /1POR to rotate towards the limit switch. Can be combined with other commands like: /1POP500R: rotate continuously until input 3 is low, then move 500 more steps.</p> <p>Bit2: /1n4R Enable Continuous Jog Mode. Continuous run of motor while switch is depressed. Velocity is given by the “V” command. Note that the jog mode allows moves below zero, which will be interpreted by any subsequent “A” command as a large positive number. If this is undesirable, please use the “z” command to define zero position to be some positive number so that underflow will not occur.</p> <p>Bit3 : /1n8R Enables Position Correction Mode. See Appendix 1</p> <p>Bit4 : /1n16R Enabled Overload Report Mode. See Appendix 1</p> <p>Bit5 : /1n32R Enable Step And Direction Mode A value of 1 for this mode, or enable Dual Encoder Mode if value of 0. i.e. /1n96<CR> (96=32+64) Enables step and dir mode and slaves the motor to it. (See Appendix 2)</p> <p>Bit6 : /1n64R Enable Motor slave to encoder/step-dir.</p>

Command (Case Sensitive)	Operand	Example	Description
POSITION CORRECTION – ENCODER OPTION ONLY			
N	1-2	/1N1R	Special Modes: 1 = Encoder with no index (default). Motor will home to the opto sensor #1, pin 7. 2 = Encoder with index. Homes to the index.
aC	1-65000	/1aC100R	When in position correction mode, set distance allowed to move before the motor corrects using encoder feedback. See Appendix 1
aE	1000-10 ⁶	/1aE12500R	Set Encoder ratio. This sets the ratio between the encoder ticks/rev and the microsteps/rev for the motor. See Appendix 1
au	1-10 ⁶	/1au10000R	Set Overload Timeout. This sets the number of times the move is retried in case a move stalls. See Appendix 1
r		/1rR	This will recover the encoder after there has been a timeout due to an overload timeout on the encoder (See Appendix 1)
PROGRAM STORAGE & RECALL			
s	0-15	/1s1A10000A OR	Stores a program. Program 0 is executed on power up (Total of 14 commands max per string when storing, but if not storing you can send 256 characters max).
e	0-15	/1e1R	Executes the Stored Programs 0-15. You can execute one program within a program. i.e. /1s0V500j2e1R, and /1s1gP1000M500G5e2R and /1s2f1Z100000R: This example will power on, execute speed of 500, 2x microstep and execute program #1: move 1000 steps and pause 0.5 seconds (5 times), then execute program 2 which will home the motor in the opposite direction.
PROGRAM EXECUTION			
R		/1R	Run the command string that is currently in the execution buffer – Always end commands with 'R'.
X			Repeat the current command string
MICROSTEPPING			
j	2, 4, 8, 16, 32, 64, 128, 256	/1j256R	Adjusts the resolution in micro-steps per step.
o (default 1500)	1400-1650		Allows user to correct any unevenness in microstep size. Adjusts audible noise and should be executed while motor is running. Should only be adjusted in small increments and should not exceed 1650 and should not be set below 1400.

Command (Case Sensitive)	Operand	Example	Description
ON/OFF DRIVERS (OUTPUTS)			
J	0-3		On/Off Driver. Turns on or off the two outputs. (I/O's are bidirectional) It's a two bit Binary value: 3=11=Both Drivers On, 2=10=Driver2 on, Driver1 off, etc. (Drivers output 3VDC max)
QUERY COMMANDS			
The following commands are queries and cannot be cascaded in strings or stored. They can be executed while other commands are still running.			
?	0	/1?0	Returns the current motor position
?	1	/1?1	Returns the current Start Velocity
?	2	/1?2	Returns the current Slew Speed for Position mode
?	3	/1?3	Returns the current Stop Speed
?	4	/1?4	Returns the status of all four inputs, 0-15 representing a 4 bit binary pattern: Bit 0 = Input 1 (Pin 13) Bit 1 = Input 2 (Pin 5) Bit 2 = Input 3 (Pin7) Bit 3 = Input 4 (Pin 14)
?	5	/1?5	Returns the current Velocity mode speed
?	6	/1?6	Returns the current step size
?	7	/1?7	Returns the current 'o' value
?	8	/1?8	Returns the Encoder Position (can be zeroed by "z" command)
?	9	/1?9	Erases all commands/program stored in EPROM except for the any settings such as current, microstepping, velocity, acceleration and any other settings
\$		/1\$	Recalls current command executed. To see what currently stored in a specific program, run the program and issue the /1\$ example: /1e2R /1\$
&		/1&	Returns the current Firmware revision and date
Q		/1Q	Query current status of the controller: 0 = No Error 1 = Initialization error 2 = Bad Command 3 = Operand out of range
T		/1T	Terminate current commands
p		/1p66	Sends out the number 66 or any number placed after p, mostly used for confirmation of when a move is done. For example /1P1000p66R will send out the number 66 when the motor has moved 1000 steps. (Any number can be used after p).
BAUD CONTROL			
	b 9600 19200 38400	/1b19200R	Adjustable baud rate This command will usually be stored as program zero and execute on power up. Default baud rate is 9600.

Responses from Controller in HyperTerminal

The SilverpakC respond to commands by sending messages addressed to the Master Device (in most cases is your PC). It always assumes it has an address of zero (0). The master device should parse the communications on the bus continuously for responses starting with /0. (It is not recommended, for example, to look for the next character coming back after issuing a command because glitches on the bus when the bus reverses direction can sometimes be interpreted as characters). After the /0 the next is the "status character" which is a collection of 8 bits.

These bits are:

Bit 7 Reserved

Bit 6 Always set

Bit 5 Ready Bit – it is set when the unit is ready to accept a command

Bit 4 Reserved

Bit 3, 2, 1, 0 represent the error codes:

0	'	No error
1	A	Initialization error
2	B	Bad command (illegal command was sent)
3	C	Bad operand (out of range operand value)
4		N/A
5	E	Communication error (internal communication error)
6		N/A
7	G	Not initialized (controller was not initialized before attempting a move)
8		N/A
9	I	Overload error (system could not keep up with commanded position)
10		N/A
11	K	Move not allowed
12		N/A
13		N/A
14		N/A
15	O	Command overflow (unit was already executing a command when another command was received)

Example of initialization error response:

The Upper nibble only takes on values of 4 or 6 in Hex. An initialization error has a response of "1" in the lower nibble. Therefore the response is 41 or 61 in Hex, which corresponds to the ASCII characters of upper case "A" and lower case "a", depending on if the device is busy or not, respectively.

Example of invalid command response:

The Upper nibble only takes on values of 4 or 6 in Hex. An invalid command has a response of "2" in the lower nibble. Therefore the response is 42 or 62 in Hex, which corresponds to the ASCII characters of upper case "B" or lower case "b", depending on if the device is busy or not, respectively.

Example of Operand Out of Range response:

The Upper nibble only takes on values of 4 or 6 in Hex. An invalid command has a response of "3" in the lower nibble. Therefore the response is 43 or 63 in Hex, which corresponds to the ASCII characters of upper case "C" or lower case "c", depending on if the device is busy or not, respectively.

Example of Overload Error Response:

The Upper nibble only takes on values of 4 or 6 in Hex. An invalid command has a response of "9" in the lower nibble. Therefore the response is 49 or 69 in Hex, which corresponds to the ASCII characters of upper case "I" or lower case "i", depending on if the device is busy or not, respectively.

Understanding Response

Example Response to the command /1?4

FF RS485 line turn around character. It's transmitted at beginning of a message

2F ASCII "/" Start character. The DT protocol uses the '/' for a start character

30 ASCII "0", this is the address of the recipient for the message.

60 This is the status character, here, 60 is " ", no error

31

31 These two bytes are the actual answer in ASCII. It will indicate the status of the 4 inputs in the form of 4 bits:

Bit 0 – switch 1

Bit 1 – switch 2

Bit 2 – opto 1

Bit 3 – opto 2

03 This is the ETX or end of text character. It is at the end of the answer string

0D This is the carriage return character

0A This is a line feed

A program that receives these responses must continuously parse for /0 and take the response from the bytes that follow /0. The first Character that comes back may be corrupted due to line turn around transients, and should not be used as a "timing mark".

Example #1:

/1gP1000D1000G10R will move motor 1000 steps counterclockwise, then 1000 steps clockwise, in a loop for 10 times.

/	Always begin a program with the forward slash
1	Address of controller (Check with the Red Dial on the unit)
g	Beginning of loop (All commands within 'g' and 'G' will repeat)
P1000	Move counterclockwise 1000 steps
D1000	Move clockwise 1000 steps
G10	End loop, repeat 10 times (G0 will repeat infinitely, type /1T to terminate)
R	Run this command

Example #2:

/1s0gH01A100H01A0G0R will store a program to memory, and run upon power up. This program will move 100 steps (90° for a 1.8° step motor) when you press a push button. And it will return to it's original position when pressing the button a second time. This will repeat infinitely.

/	Always begin programs with a forward slash
1	Address of Controller. Check on the Red Dial of the unit
s0	Store to program 0 – defined as running upon power up
g	Beginning of loop. Anything between 'g' and 'G' will repeat
H01	Halt commands until a low '0' is seen on input 1. Push button is pressed.
A100	Then move 100 steps (absolute position)
H01	Halt again until a low '0' is seen on input 1. Push button is pressed.
A0	Move back to Position 0.
G0	End loop. Repeat infinitely.
R	Run commands

To execute program, type **/1e0R**. Or, power down and power up. Only program 0 will start upon power up. To terminate out of this infinite loop, type **/1T**.

Example:**Enable Pulse Jog Mode**

/1B10000n1R (Now use inputs 1 & 2 to move 10,000 CW or CCW)

Enable Opto Limit Mode

/1n2R

/1n2gP0D0G0R

This will rotate the motor in the positive direction infinitely until it hits a switch, then it will rotate in the negative position infinitely until it hits the other switch. This will repeat continuously. (Use inputs 3 & 4)

Enable Pulse Jog Mode and Opto Limit Mode

/1n3R (Uses all 4 inputs to combine the two modes)

Enable Continuous Jog Mode

/1n4R (Now use inputs 1 & 2. Pull to ground for movements, go high to stop motion)

Enable Opto Limit Mode and Continuous Job Mode

/1n6R (Uses all 4 inputs to combine the two modes)

Homing Sensor

The "Z" command is used to initialize the motor to a generally known amount of steps (a maximum of 10000 steps + 400 default steps). When issued, i.e. /1Z5000R, the motor will turn towards zero at a maximum step of 5400 until the home opto sensor is interrupted. If issued a /1Z0R, motor will only move 400 steps to find opto sensor.

If the sensor is already interrupted, and /1Z5000R was issued, the motor will move in the opposite direction until the sensor is un-cut again. At this time, the motor moves towards home in the same way described above. When sensor is cut, motor stops motion and current position is reset to zero. Speed is set by V, i.e. /1V4000Z5000R.

The Z command is used in conjunction with Pins 6 and 7. An appropriate optical sensor must be attached to Pins 6 and 7 in order for the homing command to work properly. The Z command allows the motor to rotate until Pin 7, Input 3, goes from low to high.

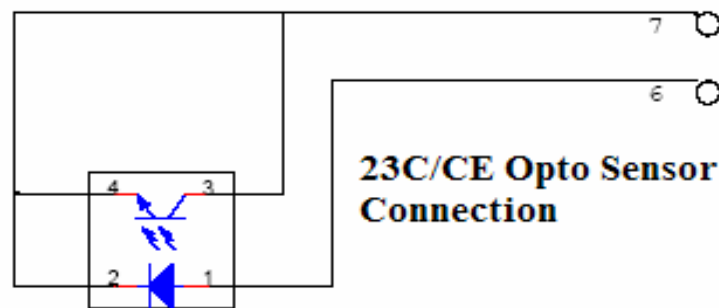

APPENDIX 1

Encoder Usage

The Silverpak 23CE **can do closed loop position correction**. The encoder connects to the board internally.

Position Correction Mode

Position correction mode, when enabled will issue steps to the motor until the encoder reads the correct position. Once enabled, positions are given in Quadrature encoder counts of the encoder – **not in microsteps**. If the motor stalls during a move then this mode will reattempt the move until the encoder reads the correct number, or until it has tried a certain number of times and times out (the au command).

First: Set The Encoder Ratio:

Encoder ratio = [(Microstep * 200 steps/rev) / (CPR * 4)] * 1000

This must be a whole number after you multiply by 1000.

For example: a 1.8° motor set to 256x microstepping with a 1000 count encoder:

Encoder ratio = ((200 * 256)/(1000*4))*1000 = 12800

Set encoder ratio: /1aE12800R

If Encoder Ratio is Unknown:

Follow these steps:

1. Issue a /1n0R to clear any special modes
2. Issue a /1z0R to set position of encoder and controller to zero
3. Issue a /1A100000R and ensure the move completes at a velocity that does not stall.
4. Issue a /1?0 to read current position. This should be 100000.
5. Issue a /1?8 to read the encoder position
6. Issue a /1aE0R which auto divides these two numbers
7. Issue a /1?aE which read backs the encoder ratio computed
8. This value is a rough guide and may be a few counts off due to inaccuracies in the motor position and run-out of the encoder, but use the EXACT number that was returned and set it with a /1aEXXXR. Or, please contact Lin Engineering and provide us with your motor part number and we can look up the encoder CPR for you.

Second: Set the Error in Quadrature Encoder Ticks allowed before correction begins:

/1aC50R (default is 50) Motor will move 50 encoder ticks away from desired position before position correction takes place. If aC is set to too small of a value, the motor may oscillate back and forth trying to locate the exact position. Use a larger aC value.

Third: Set the Overload Timeout Value:

This is the number of re-tries allowed under a stall condition: /1au10000R (default is 10)

Fourth: Enable the Feedback mode:

Zero the positions prior to enabling the feedback mode: /1z0R

Issue /1n8R to enable the feedback mode.

Overload Report Mode

Overload report mode when enabled, will compare the encoder value to the commanded position at the end of a move and report an error if the two values do not match within the range given by "aC". When this error occurs the drive will exit from any loops or strings it may be executing.

Overload report mode is enabled by /1n16R, and requires the encoder ratio to be entered correctly via the "aE" command. Issue a /1zR to zero both the encoder and position counter just prior to issuing /1n16R. Only the Position Correction mode or the Overload Report mode may be turned on at one time.

Notes:

1. When any command is received by the drive it will always respond with its status. The drive will only accept a command when it is not busy. This status byte received must be checked to ensure that the unit was not busy and that the command was accepted. This is especially important when position correction mode is enabled, because the drive may be attempting to correct position all by itself, and will reject an externally (via RS232) received command if it is busy in the middle of a correction move.
2. When position correction mode is enabled, /1n8R, then the drive will keep retrying any stalled moves, and will NOT halt any strings or loops upon detection of a stall.
3. During position correction mode /1T will halt any move, but there is a possibility that the drive may instantly reissue itself a position correction command, especially if it is fighting a constant disturbance. It may be necessary to issue a /1n0R to positively halt a move in progress.
4. Position correction mode is inhibited if the encoder underflows and goes negative (but will automatically resume if a move is made into the positive range). If position correction is required at the zero point, please redefine zero to be a slightly positive number with the "z" command. Eg /1z10000R
5. If the encoder ratio is changed from its default of 1000, the allowed max position will be decreased from $+2^{31}$ by the same ratio.

APPENDIX 2

STEP AND DRIVE MODE

1. Connect the +5V opto supply (a 5VDC power source) to Pin 4, "Opto Isolated Step and Dir +5V Power Input"
2. Connect the +ve of the step pulses to Pin 3, "Step Input (Pull Down)"
3. Connect negative -ve of step pulses to negative of the +5VDC power source and to signal ground.
4. Use Pin 11 to change direction of rotation by touching this to Pin 12, Signal ground.
5. Enable step/direction mode by issuing command /1n32R.