

17D / 17DE

INTEGRATED STEP MOTOR AND DRIVER

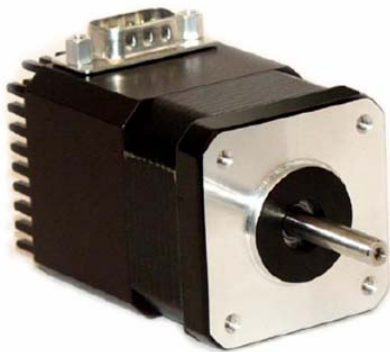

With Encoder Option

USER MANUAL

Version 1.04

Thank you for purchasing the Silverpak 17D or 17DE - Integrated Motor and R208 Driver. This product is warranted to be free of manufacturing defects for one year from the date of purchase.

Technical Support for Lin Engineering, a distributor for RMS Technologies

By Telephone: 408-919-0200

(Mon.-Fri., 8:00 a.m.-5:00 p.m.)

On the Web: www.linengineering.com

Our technical support group is glad to work with you in answering your questions. If you cannot find the solution to your particular application, or, if for any reason you need additional technical assistance, please call technical support at **408-919-0200**.

PLEASE READ BEFORE USING

Before you start, ensure that there is a suitable DC power supply. A current limited lab supply is recommended for first time users to guard against the possibility of miswiring. In addition, a suitable STEP and DIRECTION pulse source is also required.

DISCLAIMER

The information provided in this document is believed to be reliable. However, no responsibility is assumed for any possible inaccuracies or omissions. Specifications are subject to change without notice.

Lin Engineering reserves the right to make changes without further notice to any products herein to improve reliability, function, or design. Lin Engineering does not assume any liability arising out of the application or use of any product or circuit described herein; neither does it convey any license under its patent rights, nor the rights of others.

CHANGES TO THE DRIVER BOARD

The Silverpak 17D/DE is an integrated Step Motor and R208 driver.

Prior to **OCTOBER 1, 2005** the R208 driver board used slower opto-couplers, limiting the step pulse timing. The old driver board also read step pulses on the rising edge. A revision change was made on October 1, 2005, using more advanced opto-couplers. These new opto-couplers can read faster data, yet they are also more sensitive to older PLC step pulses. If your step pulse signal is not clear, the R208 will pick this up and the motor will rotate "rough" and erratic. The new boards read step pulses on the falling edge. If the falling edge of your step pulse is not a clear signal, the motor will rotate "rough" and erratic.

So far, only a small handful of customers have been affected by the change. Mostly those that use PLC's from the early 90's and older. Customers can still request the old R208 boards in quantities of 100 per order (blanket releases are OK). The old boards are under part number: R208-05.

Special Symbols



Indicates a WARNING and that this information could prevent injury, loss of property, or even death (in extreme cases).

Silverpak 17D/DE User Manual

Product: Silverpak 17D and Silverpak 17DE
Version: 1.04
Date: 8/24/2007

Version History		
Version	Date	Description of Changes
1.00		
1.01	04/10/2006	Edited Encoder information
1.02	02/02/2007	Standardization of user manuals
1.03	6/7/2007	Added min. order qty for R208-05; updated description of opto supply.
1.04	8/24/2007	Updated internal resistor info and recommended resistors for opto-isolated inputs.

TABLE OF CONTENTS

1. FEATURES 5

17DE - ENCODER FEATURES 5
DEFAULT SETTINGS 5

2. ELECTRICAL SPECIFICATIONS 6

POWER SUPPLY REQUIREMENTS 6
DRIVER 6
MOTOR SPECIFICATIONS 6
LOGIC INPUT TIMING 7

4. MECHANICAL SPECIFICATIONS 7

DIMENSIONS 8

5. CONNECTORS 9

6. GETTING STARTED 10

ALTERNATIVE STEP RESOLUTION CONNECTION 11

7. CONFIGURING AND CONTROLLING THE 17D 11

SIGNAL CONTROL SPECIFICATIONS 11
INTERNAL SCHEMATIC 12
RESISTOR VALUES FOR THE OPTO SUPPLY 12

8. TROUBLESHOOTING 13

FEATURES

- NEMA Size 17, 2 Phase, 1.8° Bipolar Step Motor w/ Built-In Microstepping Driver
- Operates from +12 to 24 VDC
- Step Resolution: Full, 1/2, 1/4, 1/8
- Optically Isolated Step, Direction, and Disable/Enable Inputs
- Automatic Current Reduction with Disable Switch
- Low Power Dissipation
- Efficient Current Control
- Quiet Operation
- Thermal Shutdown, Under-Voltage Protection
- Power-On Indicator
- Power Disable/Enable Control
- Sinusoidal current waveform
- Phase Current Range from 0.35 to 2.0 Amp
- Default Setting is 1.0 Amp RMS or, 1.4 Amp Peak

17DE - Encoder Features

- 32 to 1250 cycles per revolution (CPR) chosen by customer
- 2 Channel Quadrature
- TTL Squarewave Outputs and optional index (3rd Channel)
- E2 US Digital Encoder

Pin Number	Function
1	Ground
2	Index*
3	Channel A
4	+ 5 VDC
5	Channel B

Table 1: Encoder Pinouts

*Optional Index Channel

Default Settings

Default Settings	
Step Resolution	8x Microstep
Direction of rotation	Counterclockwise
Holding Current	23% of motor's rated Current

Table 2

The 17D is set to these default settings when Pins 2, 3, 4, and 5 are left open.

2. ELECTRICAL SPECIFICATIONS

Power Supply Requirements

Voltage +12 VDC to +24 VDC

Driver

Peak Current: 0.35 to 2.0 Amps OR 0.25 to 1.4 Amps

Motor Specifications

NEMA Size 17

Holding Torque (default – 23% holding current):

DO-4118S 34.5 oz-in

DO-4118M 48.5 oz-in

DO-4118L 63.9 oz-in

Holding Torque (special* – 100% holding current):

DO-4118S 45 oz-in

DO-4118M 63 oz-in

DO-4118L 83 oz-in

Steps per Revolution (1.8° Motor)

200, 400, 800, 1600

*NOTE: The Silverpak 17D/DE by default use 23% of the run current as it's hold current. If you require more holding torque, the other option is to use 100% of the run current as your holding current, which must be special ordered.

3. OPERATING SPECIFICATIONS

Operating Temperature: -20° to 50° Celsius
Humidity Range: 0 to 95% (non-condensing)

100% duty cycle is OK as long as bottom of unit is 50°C or less (bottom of unit is where the black heat sink fins are located)

Logic Input Timing

(A) Minimum Command Active Time Before Step Pulse (Data Set-up Time)	200 nanoseconds
(B) Minimum Command Active Time After Step Pulse (Data Hold Time)	200 nanoseconds
(C) Minimum Step Pulse Width	20 microseconds
(D) Minimum Step Low Time	20 microseconds
(E) Maximum Power-Down Recovery Time	20 milliseconds
Maximum Step Frequency	25 kHz

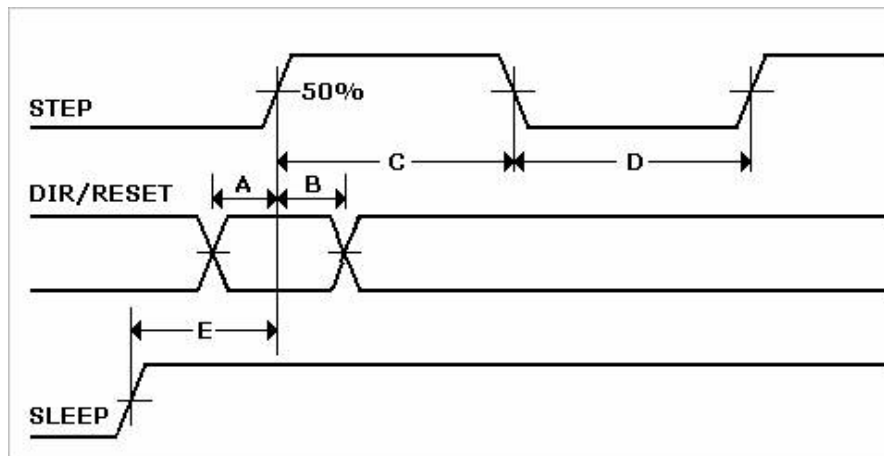

Figure 1: Timing Diagram

4. MECHANICAL SPECIFICATIONS

A. Motor Front Shaft Extension Length

Standard length is 0.94". Customized length is available.

B. Motor Shaft Diameter

Standard shaft diameter is 0.1968". Customized diameter length is also available.

C. Overall Body Length

Motor body length is available in various lengths

DO-4118S	(2.69")
DO-4118M	(2.92")
DO-4118L	(3.24")

Dimensions

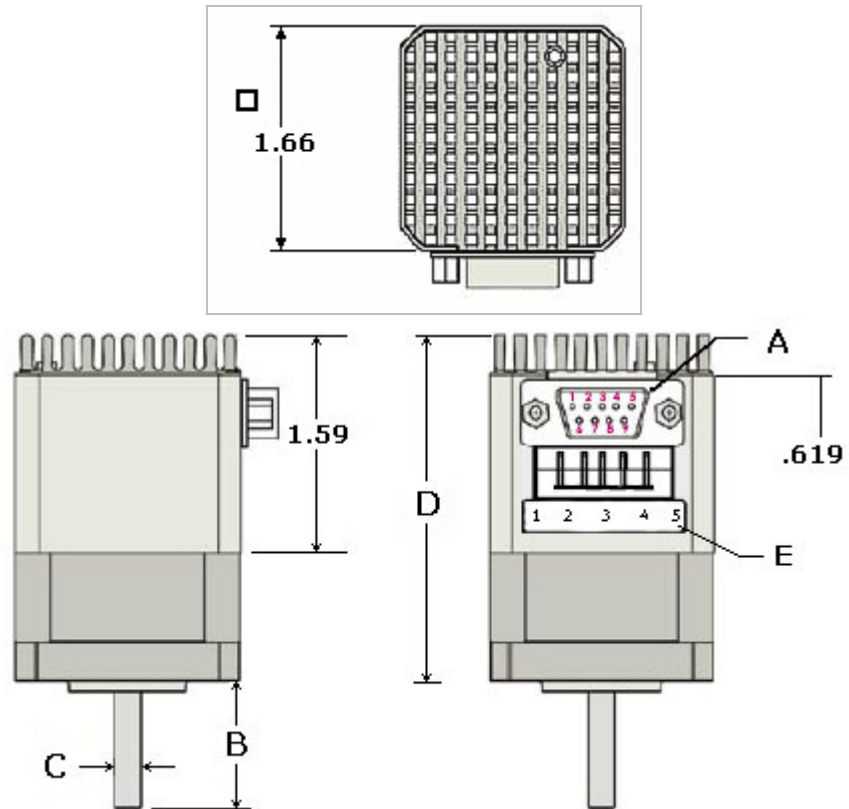

Figure 2: Dimensions Diagram

5. CONNECTORS

A DB-9 female connector cable receives power and provides the control connections for the 17D Unit. Active signals are optically isolated. An open-collector drive is required to provide pulses for Step, levels for Direction and Disable/Enable.

PIN #	COLOR (#26 AWG Lead)	FUNCTION	DESCRIPTION
1	Red	+V	Motor Supply Voltage. +12 to +24 VDC
2	Black	SR1 Input	Step Resolution 1. Pins 2 & 3 are used to preset the step resolution by selective contact to ground (Pin 7)
3	Brown	SR2 Input	Step Resolution 2. Pins 2 & 3 are used to preset the step resolution by selective contact to ground (Pin 7)
4	Black/White	Enable/Disable Input	This input is used to enable/disable the output of the driver
5	Orange	Direction Input	This input is used to change the rotation direction of the motor
6	Green	Power Ground	The ground or return of power supply connects here.
7	White	Logic Ground	Used to ground to the logic functions (i.e. step resolution)
8	Blue	Opto Supply	+5 VDC input used to supply power to the isolated logic inputs**
9	Yellow	Step Clock	Connects to the open-collector drive.

Table 3: Pin Assignments



WARNING! - Do not apply differential voltage on SR1 and SR2, this will damage the driver.

** The Resistors shall be connected in series with each Input: Pin 4 (Disable), Pin 5 (Direction), and Pin 9 (Step) if you are to use an opto supply of more than +5VDC. See Section 7.



Figure 3: DB-9 Female Cable Connector (Rear View)

6. GETTING STARTED

In order to properly connect your new 17D Unit, first take a look at Figure 4, below. Here's a list of the parts needed to make the motor run:

- +12 to 24 Volt Power Supply
 - Additional +5 Volt Power Supply
 - Function Generator
1. Ensure that the 17D is not connected to the Main Power Supply until the following procedures have been properly carried out.
 2. Connect Pin 8 to the Positive Terminal of the +5 VDC Power Supply.
 3. Connect the Negative Terminal of the +5 VDC Power Supply to the Negative Terminal of the Signal Generator. This will be referred to as the Signal Ground.
 4. Connect Pin 1 and Pin 6 to the Positive and Negative Terminals of the Main Power Supply, respectively.
 5. Adjust the Frequency of the Signal Generator to achieve the desired operating speed.

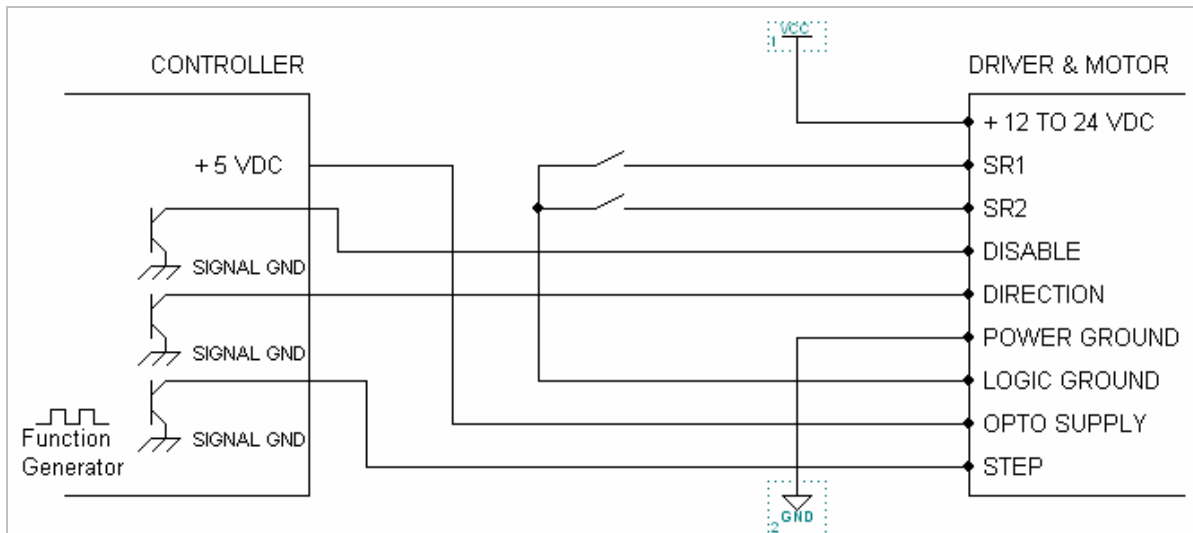

Figure 4: Connections Diagram

WARNING! DO NOT DISCONNECT THE DB-9 CABLE FROM THE 17D UNIT WHILE POWER IS STILL BEING SUPPLIED. THIS MAY CAUSE DAMAGE TO THE INTERNAL DRIVER BOARD.



WARNING! If you do not have a +5 VDC Power Source, use a Resistor in series to limit the current of the opto isolators. See following page for Resistor values. **If the current exceeds 10 mA, the opto couplers cease to function.**

ALTERNATIVE STEP RESOLUTION CONNECTION

It is possible to change the microstepping resolution by using the signal from the controller.

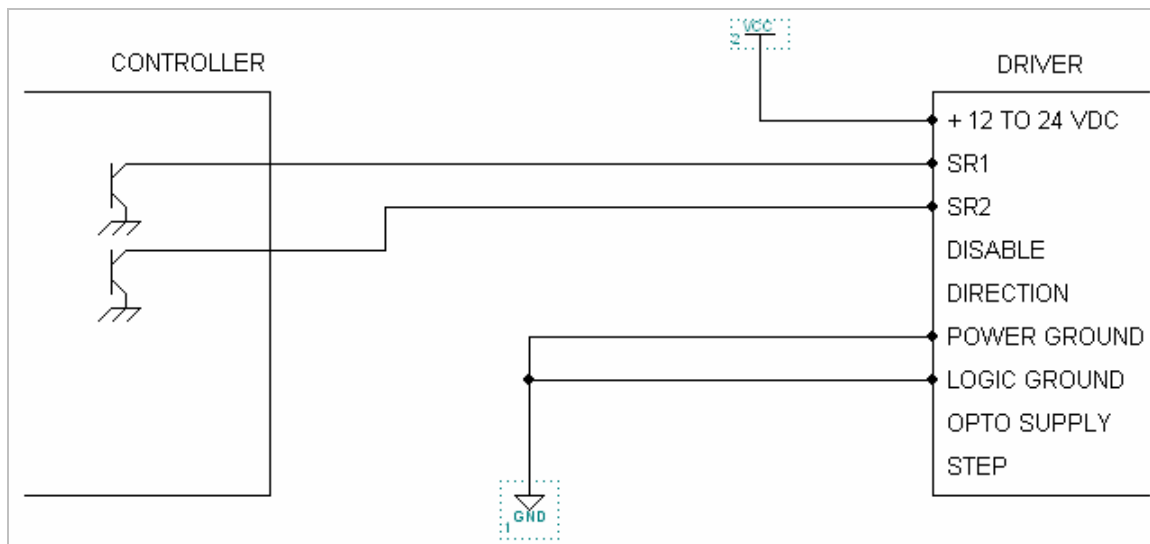

Figure 5: Alternative Step Resolution Connection

By sending a high signal to Pin 2 and/or Pin 3, the connection between these pins will be effectively closed with Pin 7. This will change the microstepping resolution. Please refer to the *Table 3* for Step Resolution Settings.

PLEASE NOTE: The microstepping resolution should not be changed on the fly, loss of step may occur.

7. CONFIGURING AND CONTROLLING THE 17D

SIGNAL CONTROL SPECIFICATIONS

Step Resolution	SR1 (Black)	SR2 (Brown)
Full	Close	Close
Half	Close	Open
1/4	Open	Close
1/8	Open	Open

Table 4: Step Resolution Settings
SR1 (Pin 2) and SR2 (Pin 3) are used to preset the step resolution by selective contact closure to ground (Pin 7).

WARNING! Do not change the Step Resolution on the fly, loss of step will occur.

Enable/Disable	
Enable	Open
Disable	Close

Table 5: Enable/Disable Settings
Disable the Driver by closing the connection between Pin 4 and Signal Ground.

Direction	
Clockwise	Close
Counterclockwise	Open

Table 6: Direction Settings
Change direction of rotation by closing the connections between Pin 5 and the Signal Ground.

INTERNAL SCHEMATIC

The 17D has 3 optically isolated logic inputs. These inputs are isolated to minimize or eliminate electrical noise coupled onto the drive control signals. Each input is internally pulled-up to the level of the optocoupler supply and may be connected to sinking outputs on a controller or a PLC. These inputs are:

- Enable/Disable (Pin 4)
- Direction (Pin 5)
- Step Clock (Pin 9)

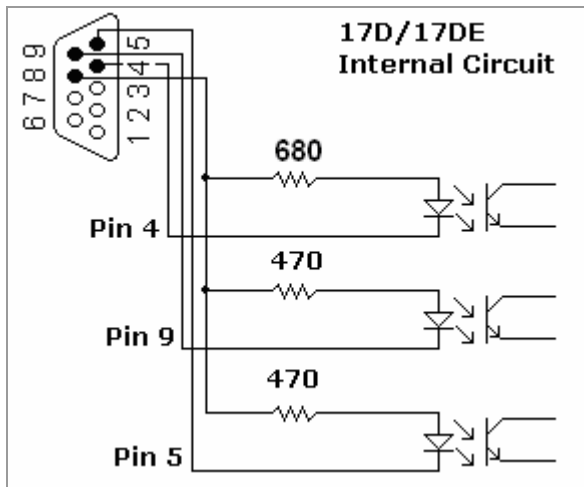

Figure 6: Optically Isolated Inputs

Within the Driver lies three 680 Ω Resistors and three Optocouplers. The current is limited to 7 mA due to these three Opto Couplers.

Resistor Values for the Opto Supply

The optocouplers must be powered by an external power supply to maintain isolation. The Opto Supply for the optocouplers can be between +5 to 24 VDC with respect to the signal input. It is recommended to use a +5 VDC Opto Supply in order to limit the current going into the optocouplers to 10 mA. However, if the supply is greater than +5 VDC then a resistor must be connected in series with each signal line to maintain 10 mA of current running through the optocouplers. **Do NOT provide more than 10 mA or damage may occur to the driver.** Refer to *Table 7 & 8* for the corresponding Resistor Values.

The Resistors shall be connected in series with each Input: Pin 4 (Disable), Pin 5 (Direction), and Pin 9 (Step).

Step & Direction lines have a 470 ohm internal resistor

Voltage:	5V	10V	15V	24V
Ohms needed:	0	500	1000	2000
Wattage rating:	0	¼ watt	¼ watt	½ watt

Disable line has a 680 ohm internal resistor

Voltage:	5V	10V	15V	24V
Ohms needed:	0	750	1500	2700
Wattage rating:	0	1/8 watt	¼ watt	½ watt

Table 7 & 8: Resistor Values for inputs

8. TROUBLESHOOTING

The Motor is in Holding Position, but does not rotate.

This means that Power is being supplied to the driver and motor, so the power supply is OK. However, the signal generator might be causing the problem. Try changing the signal to TTL. If this doesn't help, is the external +5 VDC Power connected? Is Pin 4 (disable) touching Pin 7 (logic ground)? This will disable the driver from running.

The Microstepping does not always change to the correct step resolution.

Changing the microstepping "on the fly" might ruin the driver. It is recommended to disable the motor from running (either turn power off, or use the disable pin), then change the step resolution.