

FEATURES

- Absorbs vibration and decreases resonance
- Smoother motion
- Durable
- Easy installation
- Cost effective

SPECIFICATIONS

Part Number	Inertia oz-in ² (gm-cm ²)	Weight lb. (g)	Mounting (Screw Type)	Shaft Size in. (mm)	Wet/Dry Operation	COMPATIBLE MOTORS	
						0.9°	1.8°
057-00006	0.36 (65.84)	0.15	Set Screw (M4)	0.2500 (6.35)	Dry	5609, 5709	5618, 5718, 5818

DIMENSIONS

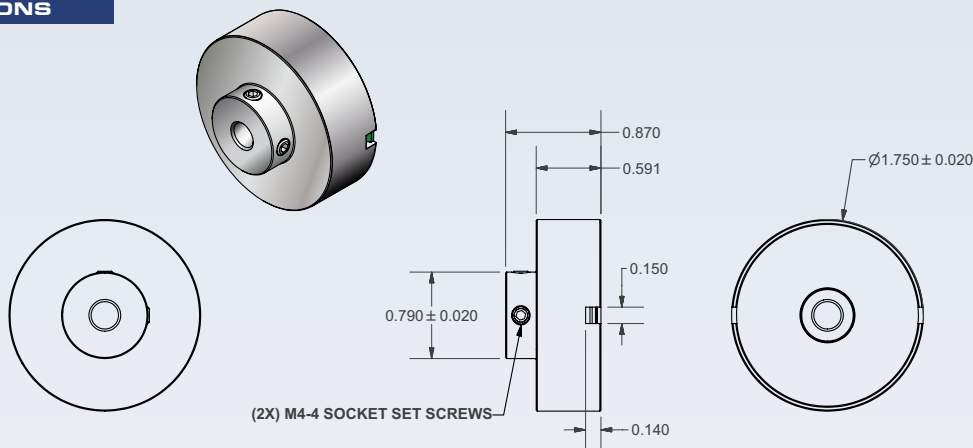

COMPARISON

As motors step, inertia makes the rotor oscillate about its new position (the motor's settling time). This natural back and forth movement might sometimes contribute to the erratic movement of motors. Adding a Lin damper to the step motor's shaft translates into smaller oscillations and thus, smoother motion. This reduced step response time can ultimately result in much improved motor performance.

Here is a comparison of one motor's settling time with and without the use of a damper.

Without Damper = 0.15 Seconds
With Damper = 0.036 Seconds
That's up to 4 times less resonance when you use a damper from Lin Engineering

