

FEATURES

- NEMA Size 23, 2 phase, 1.8° bipolar step motor w/ Built-in microstepping Driver
- Up to 294 oz-in of holding torque
- Operates from +12 to 75 VDC
- Phase currents from 0.1 to 5.0 Amps Peak
- Step resolutions from Full Step to 256x microstepping and from 5x to 250x
- Four selectable damping modes for smooth motion
- Uses the new Lin Driver GUI software to set parameters
- Pole Damping Technology™

SPECIFICATIONS

- **INPUT VOLTAGE:**
+12 to 75 VDC
- **DRIVE CURRENT(PER PHASE):**
0.1 to 5.0 Amps Peak
- **OPTICALLY ISOLATED INPUTS:**
Step, Direction, and Disable
- **STEP FREQUENCY (MAX):**
5.0 MHz
- **STEPS PER REVOLUTION (1.8° MOTOR):**
200, 400, 800, 1600, 2000, 3200, 5000, 6400, 10000, 12800, 25000, 25600, 50000, 51200
- **MICROSTEP RESOLUTIONS (1.8° MOTOR):**
Full, 2x, 4x, 8x, 10x, 16x, 25x, 32x, 50x, 64x, 125x, 128x, 250x, 256x
- **POLE DAMPING TECHNOLOGY™:** See page 8.

DIMENSIONS

A. Overall Body Length
DOP-5718X: 2.65" (67.31 mm)
DOP-5718M: 3.16" (80.26 mm)
DOP-5718L: 4.03" (102.3 mm)

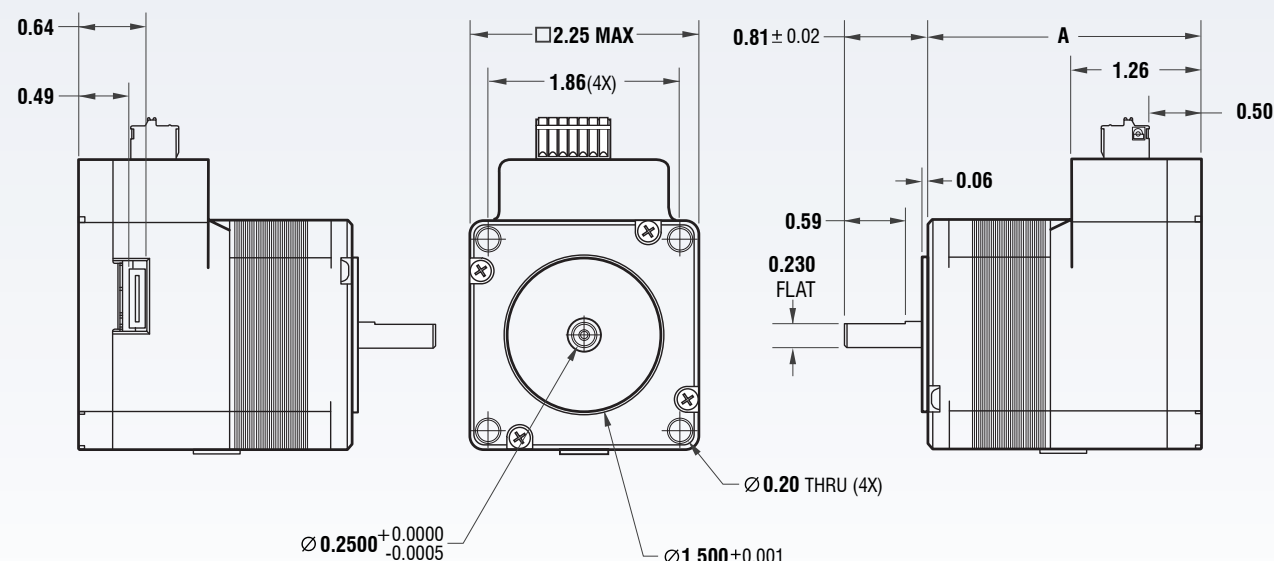

Visit Lin Engineering's web site for dimension updates.

TORQUE CURVES

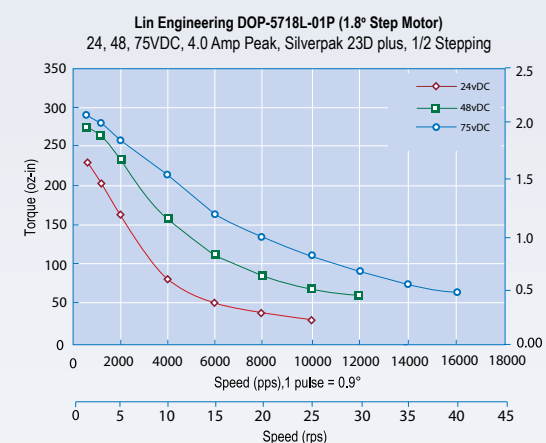
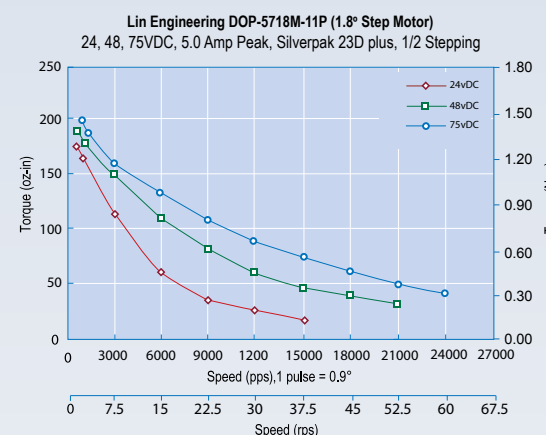
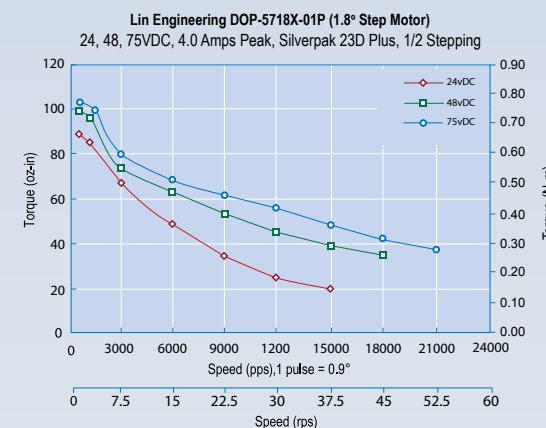

MOTOR SPECIFICATIONS

Model DOP-5718X-01P
Holding Torque oz-in (N-m) 100.0 (0.71)
Rotor Inertia oz-in² (kg-cm²) 0.7 (0.13)
Weight (Motor + Driver) lbs (kg) 1.2 (0.55)

Model DOP-5718M-11P
Holding Torque oz-in (N-m) 173.0 (1.22)
Rotor Inertia oz-in² (kg-cm²) 1.50 (0.27)
Weight (Motor + Driver) lbs (kg) 1.65 (0.75)

Model DOP-5718L-01P
Holding Torque oz-in (N-m) 294.00 (2.08)
Rotor Inertia oz-in² (kg-cm²) 2.60 (0.47)
Weight (Motor + Driver) lbs (kg) 2.35 (1.07)

OPTIONAL ENCODER

Optional encoder available with SilverPak 23DE Plus

Encoder features:

- Max 1,250 cycles per revolution (CPR)
- Max 5,000 pulses per revolution (PPR) (quadrature)
- 2 channel quadrature TTL squarewave outputs
- Optional index (3rd channel)
- Position correction capabilities with user's external controller



SHAFT MODIFICATIONS



For more shaft modifications options, see page 69.