



MOTOR NUMBERING SYSTEM

STEP MOTOR NUMBERING SYSTEMS

System 1

Example: 417-07-07DE-01-RO

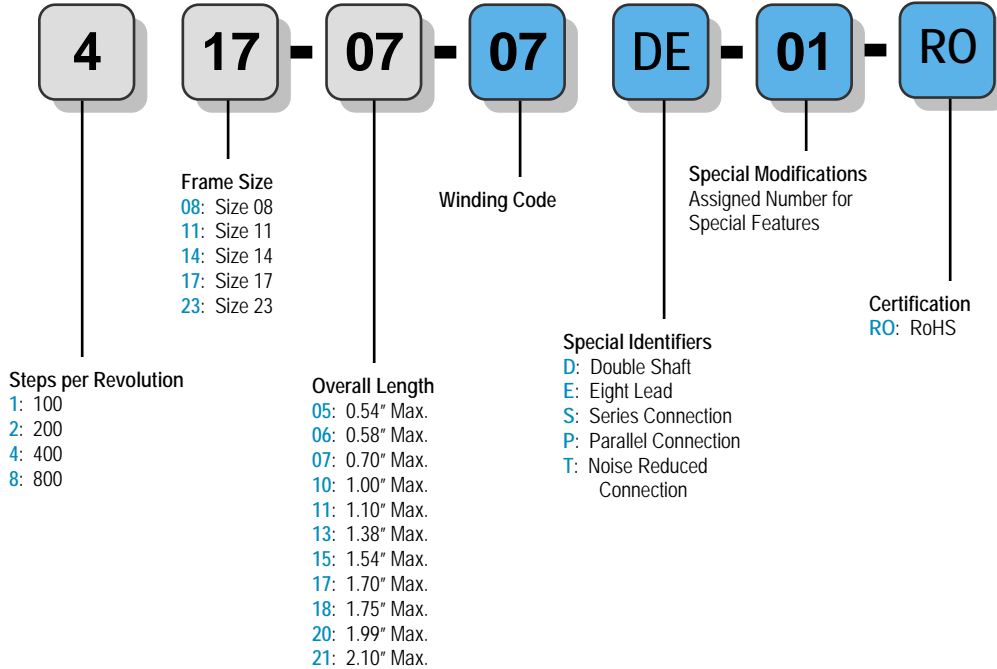

System 2

Example: 5618M-01DE-01-RO

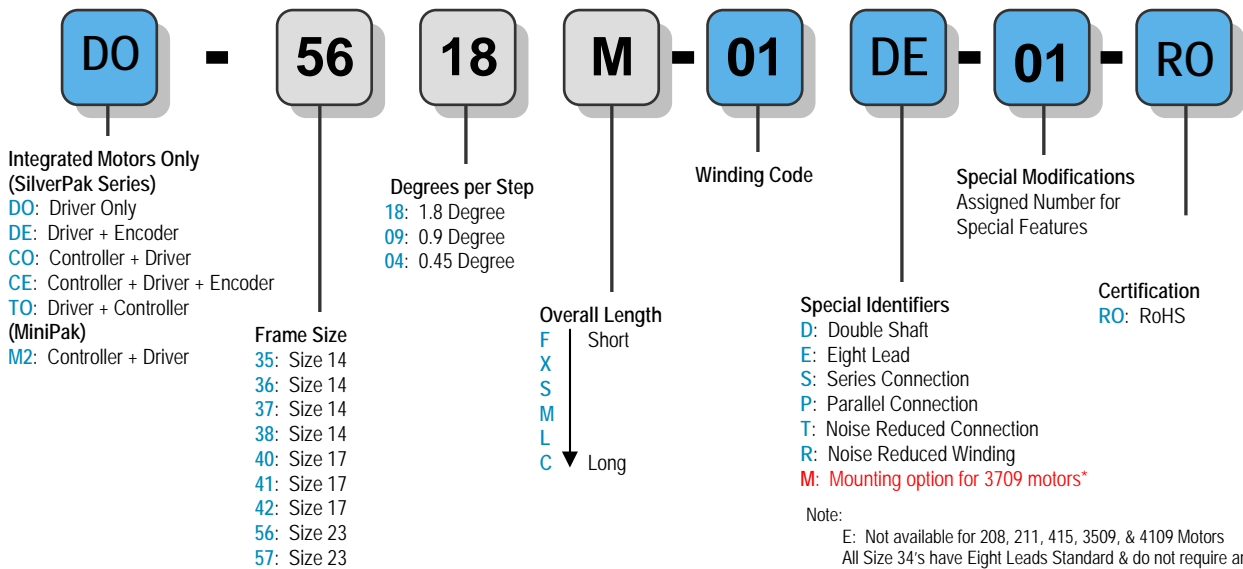

*Mounting option key:
 M1, SIGNATURE, CAST, MTG SIZE 17, #4-40 UNC
 M2, SIGNATURE, CAST, MTG SIZE 17, M3 X 0.5
 M3, SIGNATURE, CAST, MTG SIZE 17, 0.130 THRU
 M4, SIGNATURE, CAST, MTG SIZE 14, #4-40 UNC
 M5, SIGNATURE, CAST, MTG SIZE 14, M3 X 0.5
 M6, SIGNATURE, STAMPED, MTG SIZE 17, M3 X 0.5
 M7, SIGNATURE, STAMPED, MTG SIZE 17, 0.130 THRU

Brushless DC Motor Numbering System

Example: BL24A52-01D-01

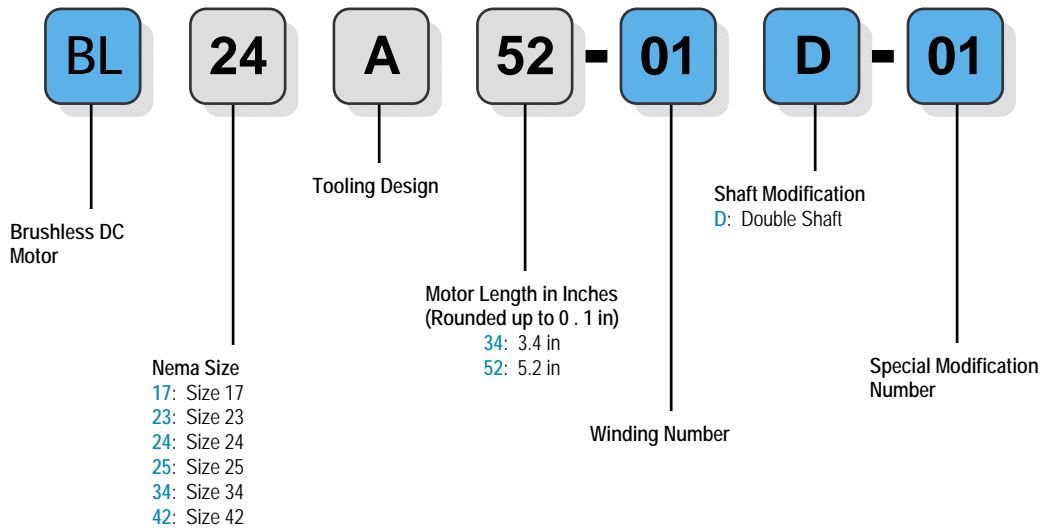

Driver / Controller Numbering System

Example: R325-IE

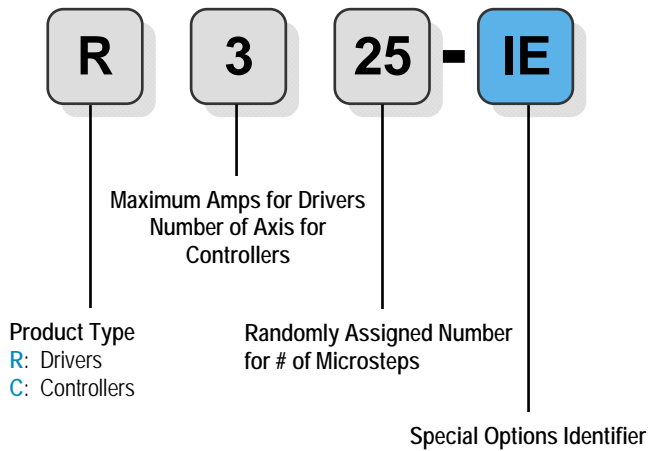

Motor with Integral Driver/Controller Numbering System

Example: DE- 4118S- 01- PD- 01

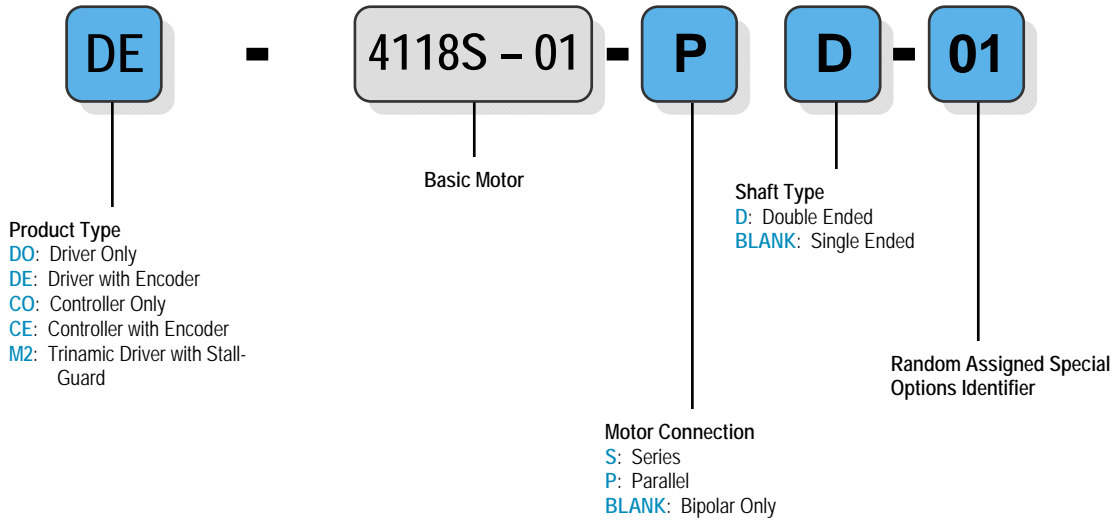

OR

Motor with Integral Driver/Controller Numbering System

Example: DE-4118S- 01- PD- 01

